



UNIVERSITAT POLITÈCNICA  
DE CATALUNYA



# The role of MDA in the Control and Management plane of Metro Networks

**Luis Velasco**

[lvelasco@ac.upc.edu](mailto:lvelasco@ac.upc.edu)

# Central Office Architecture

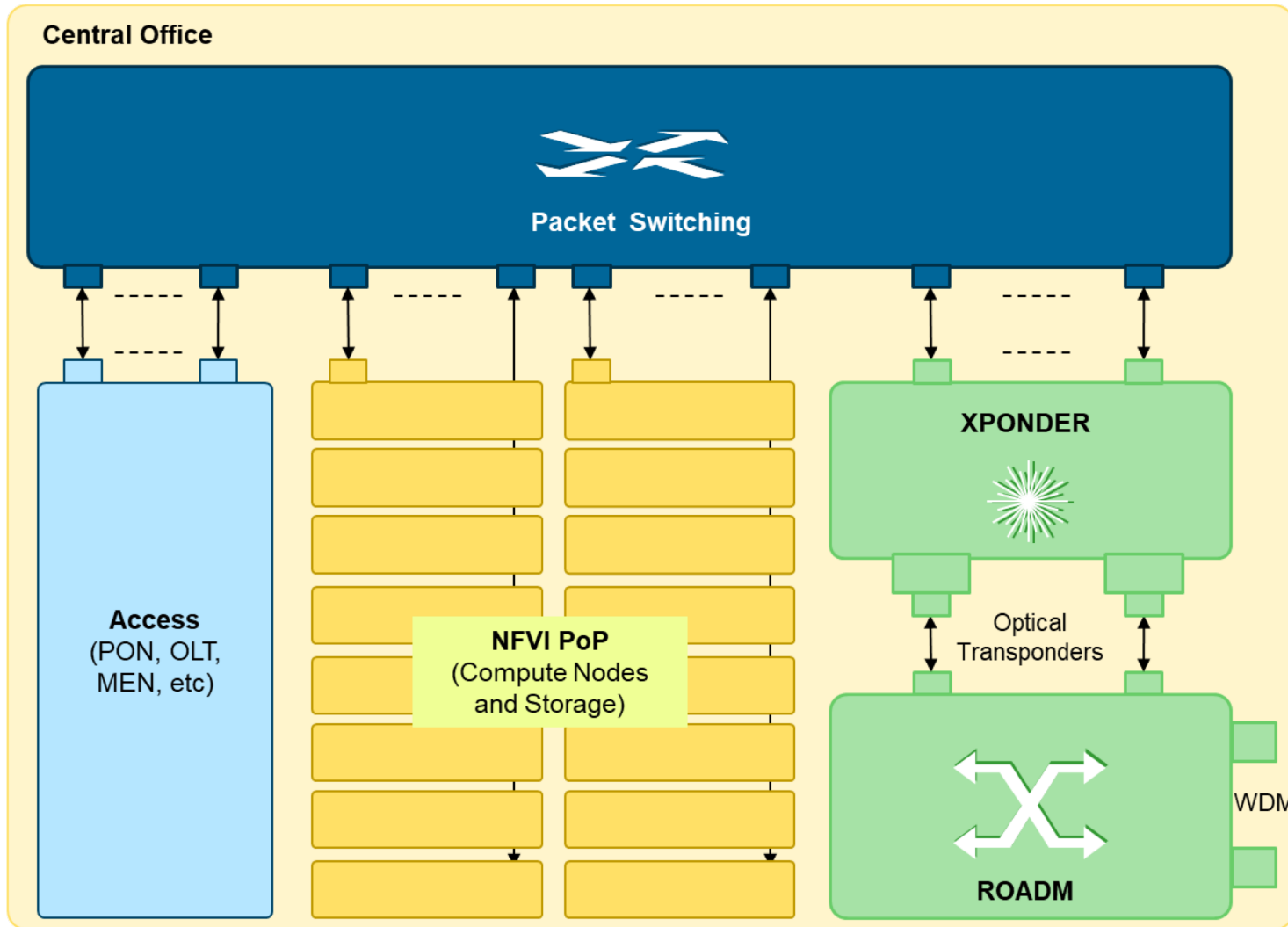

L. Velasco et al., "Building Autonomic Optical Whitebox-based Networks," IEEE/OSA JLT, 2018.

# Orchestrating the Telecom Cloud

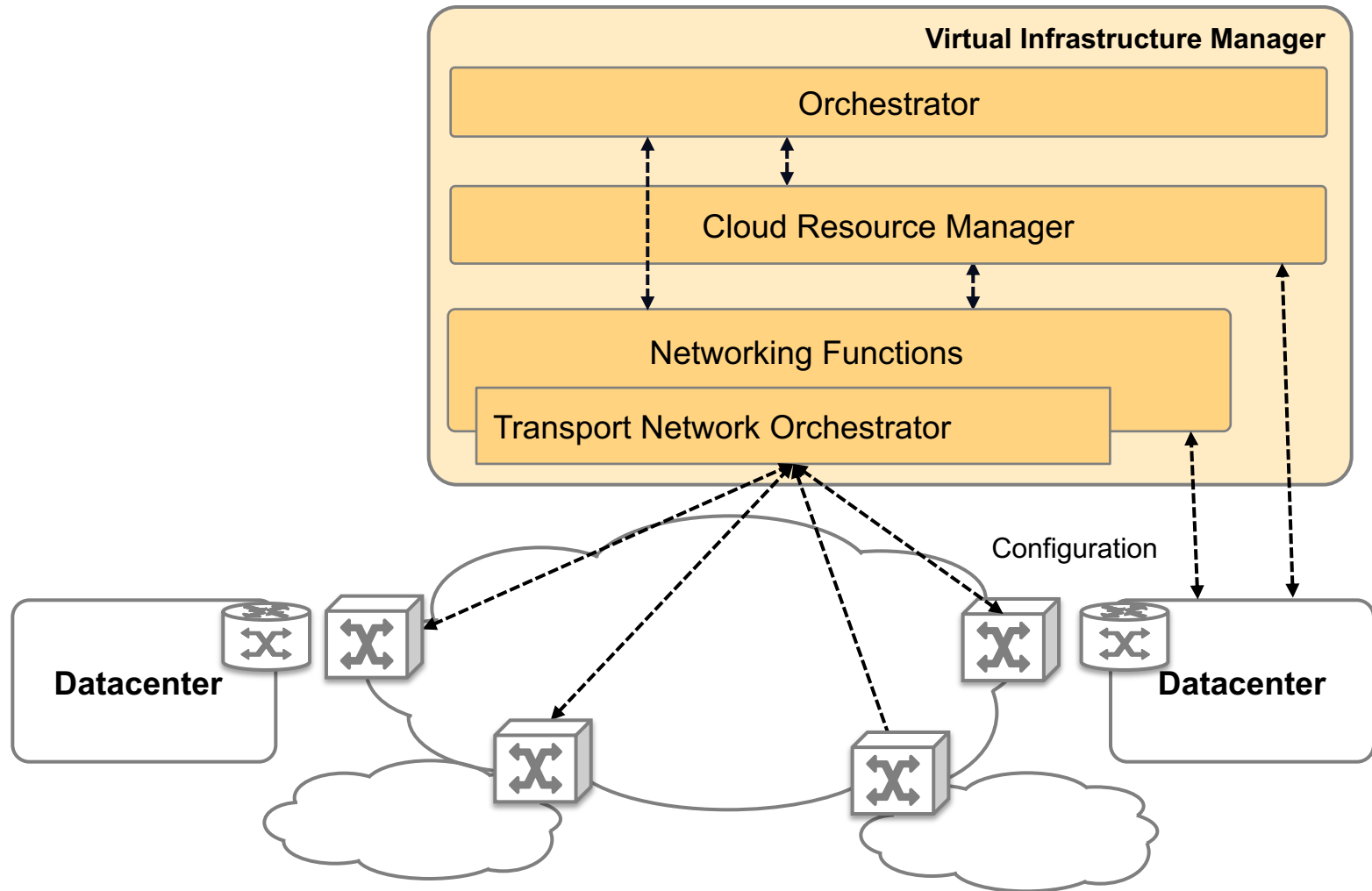

# Applying Control Loops

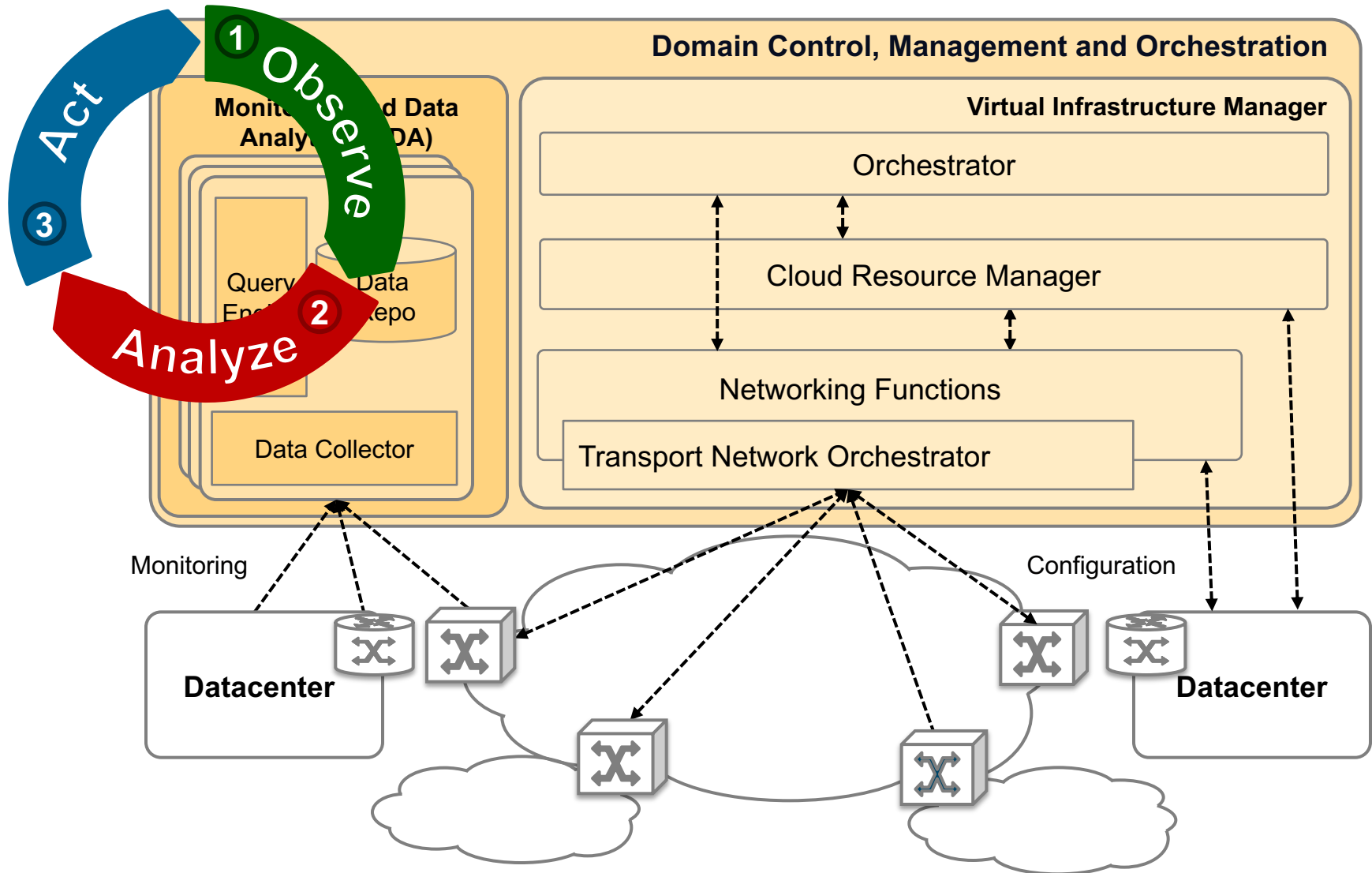



# Architecture Overview

- **Single** monitoring and data analytics architecture for the whole infrastructure
- The MDA **connects virtualized components** together and enables **secure data exchange** among them.

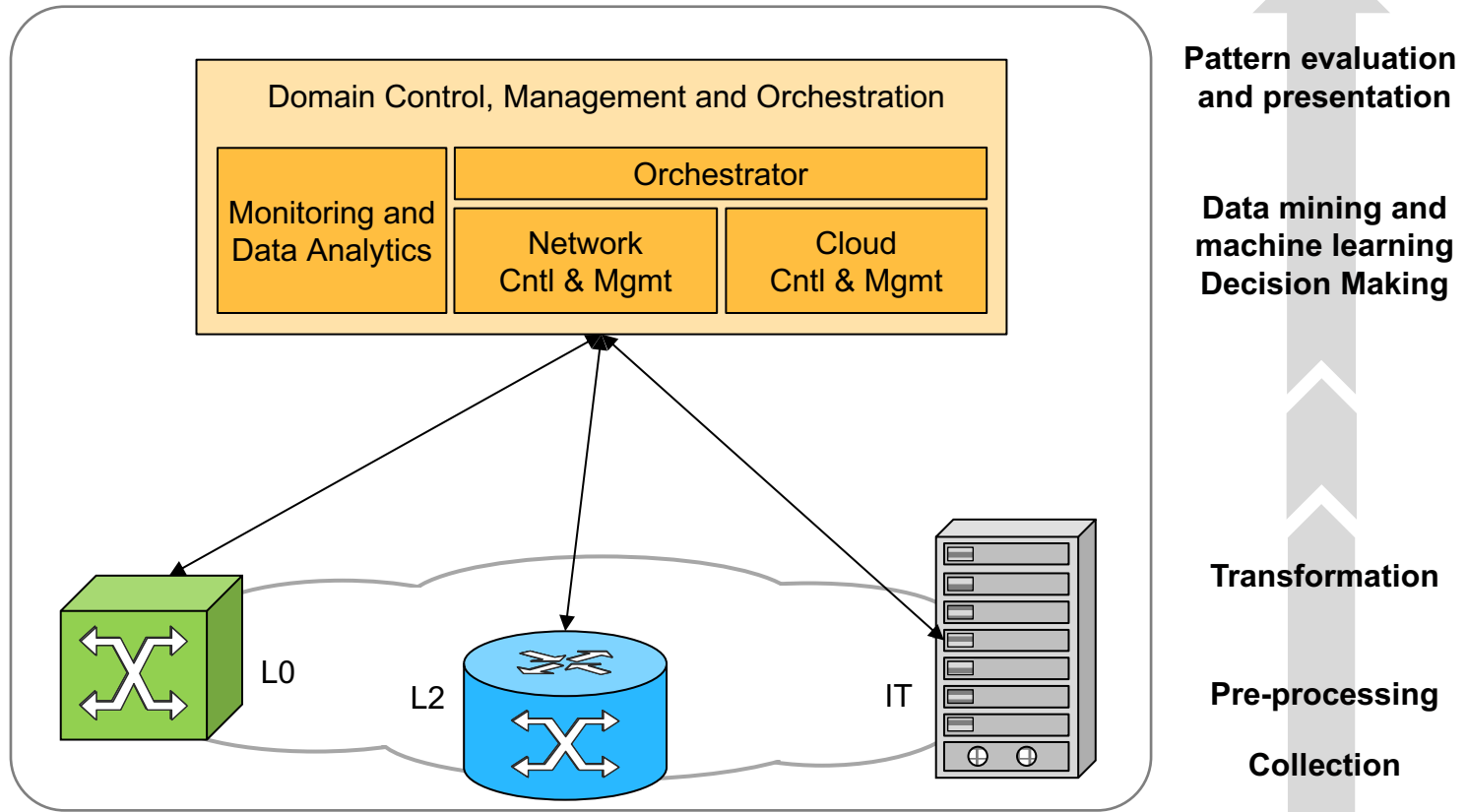

# Observation Points

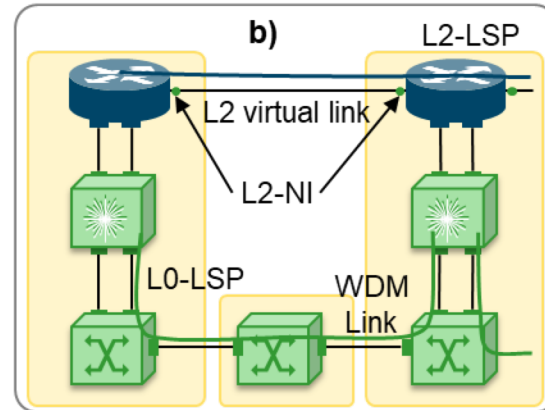
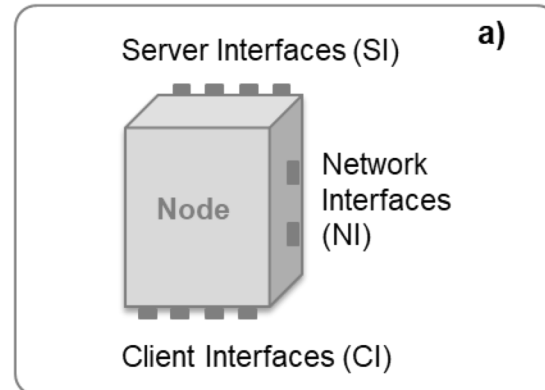

**Monitorable components and data measured** **d)**

1. L2-SI: Ethernet aggregated traffic
2. L2-NI: L2 aggregated traffic
3. L0-CI: Average optical power
4. L0-SI: Average optical power
5. L0-NI: Average optical power
6. L2-LSP: L2-LSP traffic
7. L0-LSP: L0-LSP BER and opt. power

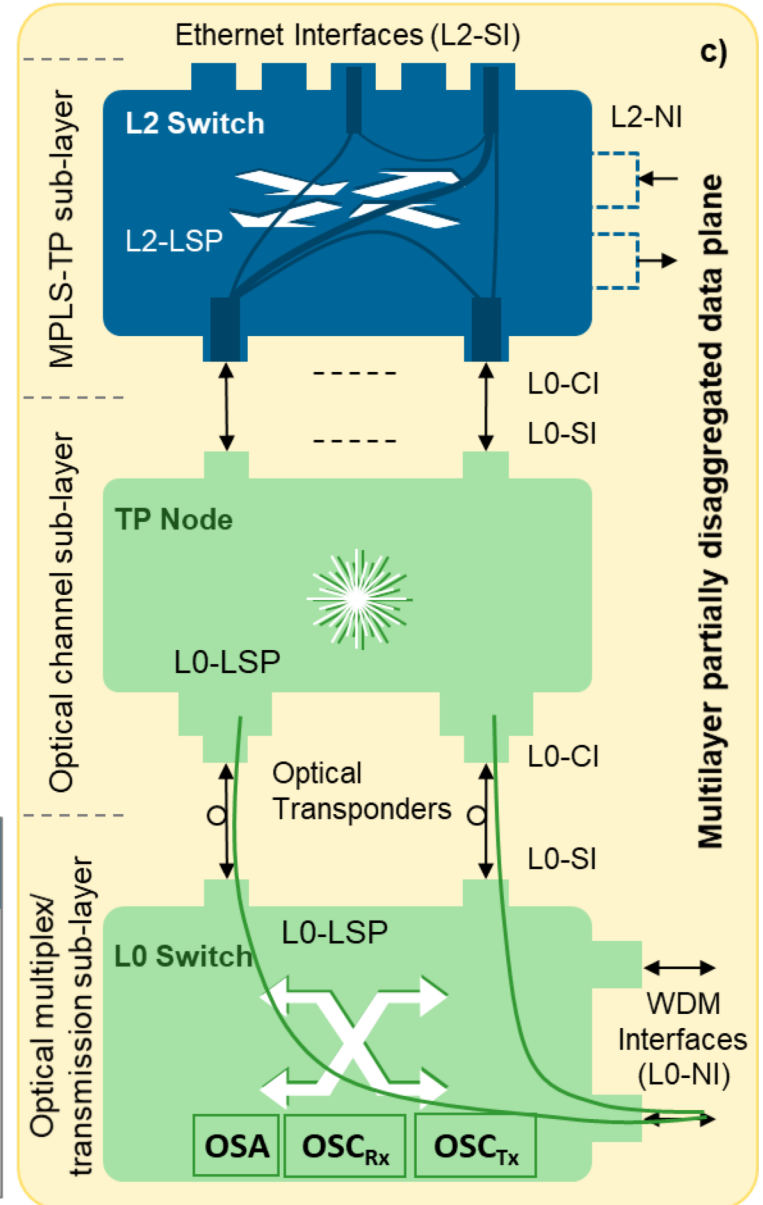

L. Velasco et al., "Building Autonomous Optical Whitebox-based Networks," IEEE/OSA JLT, 2018.

# Bringing Data Analytics to the Network Nodes

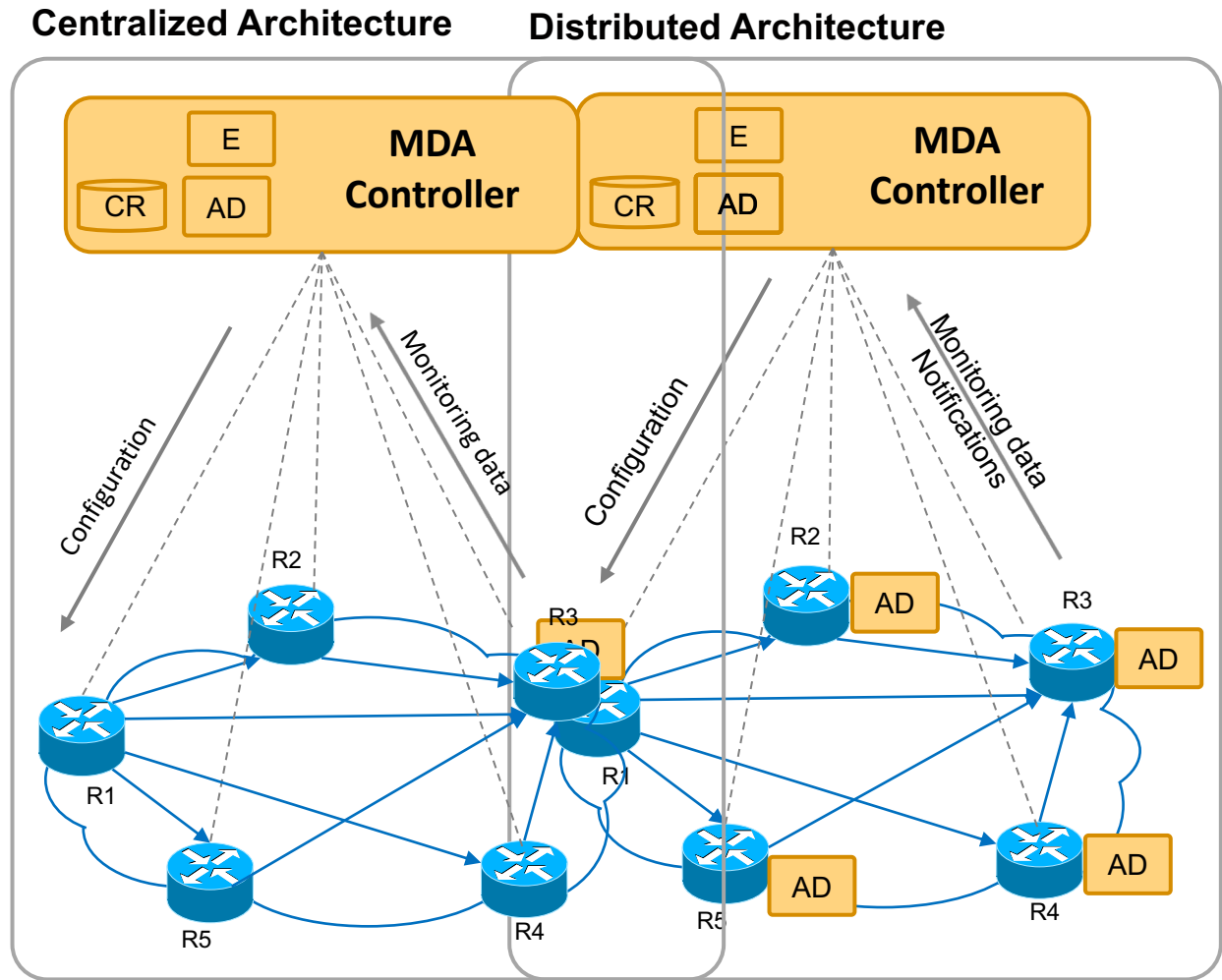

A. P. Vela et al., "Distributing Data Analytics for Efficient Multiple Traffic Anomalies Detection," *Elsevier Computer Communications*, 2017.



UNIVERSITAT POLITÈCNICA  
DE CATALUNYA



# MDA and COM Architecture

# Conceptual COM Architecture

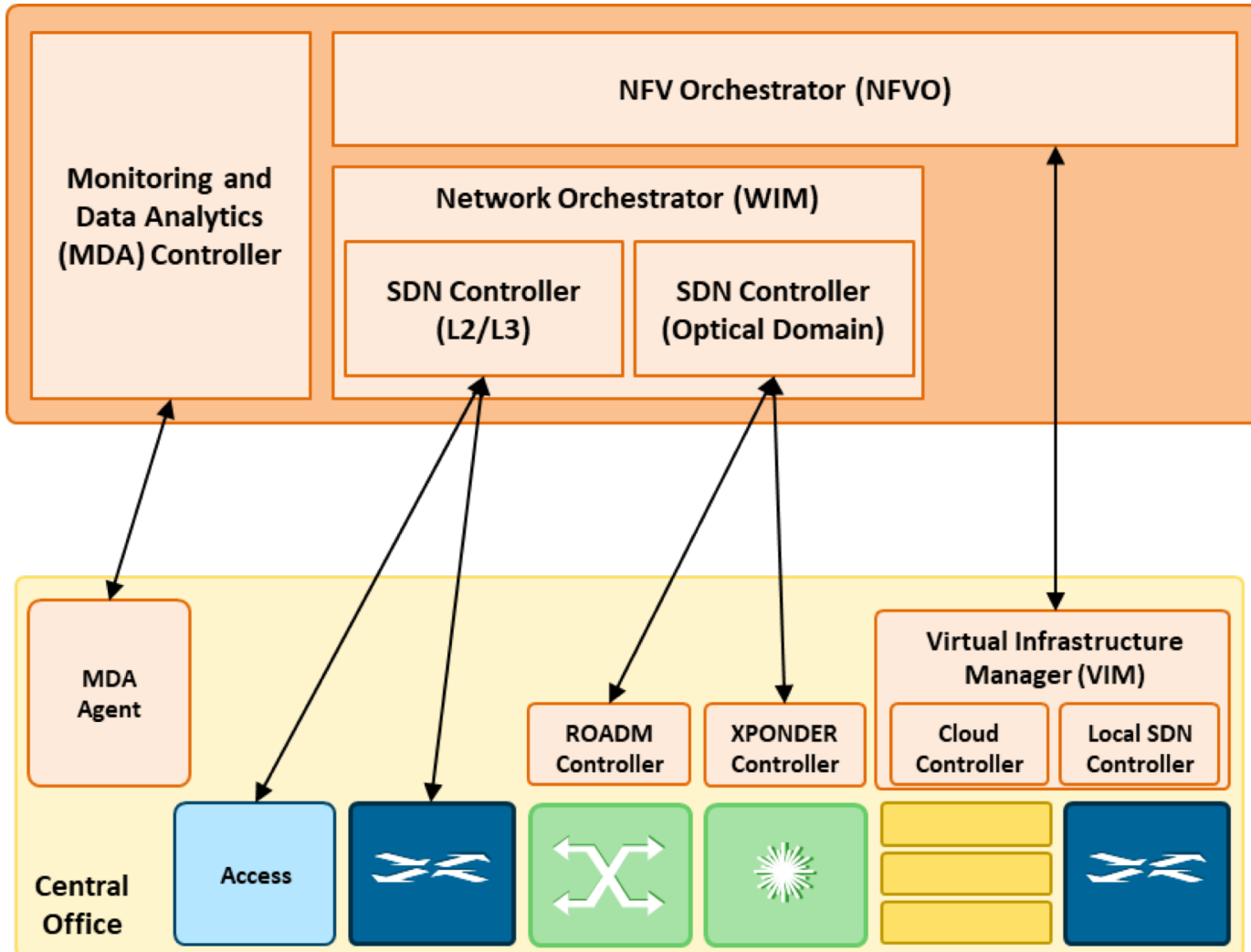

# Architecture and Interfaces

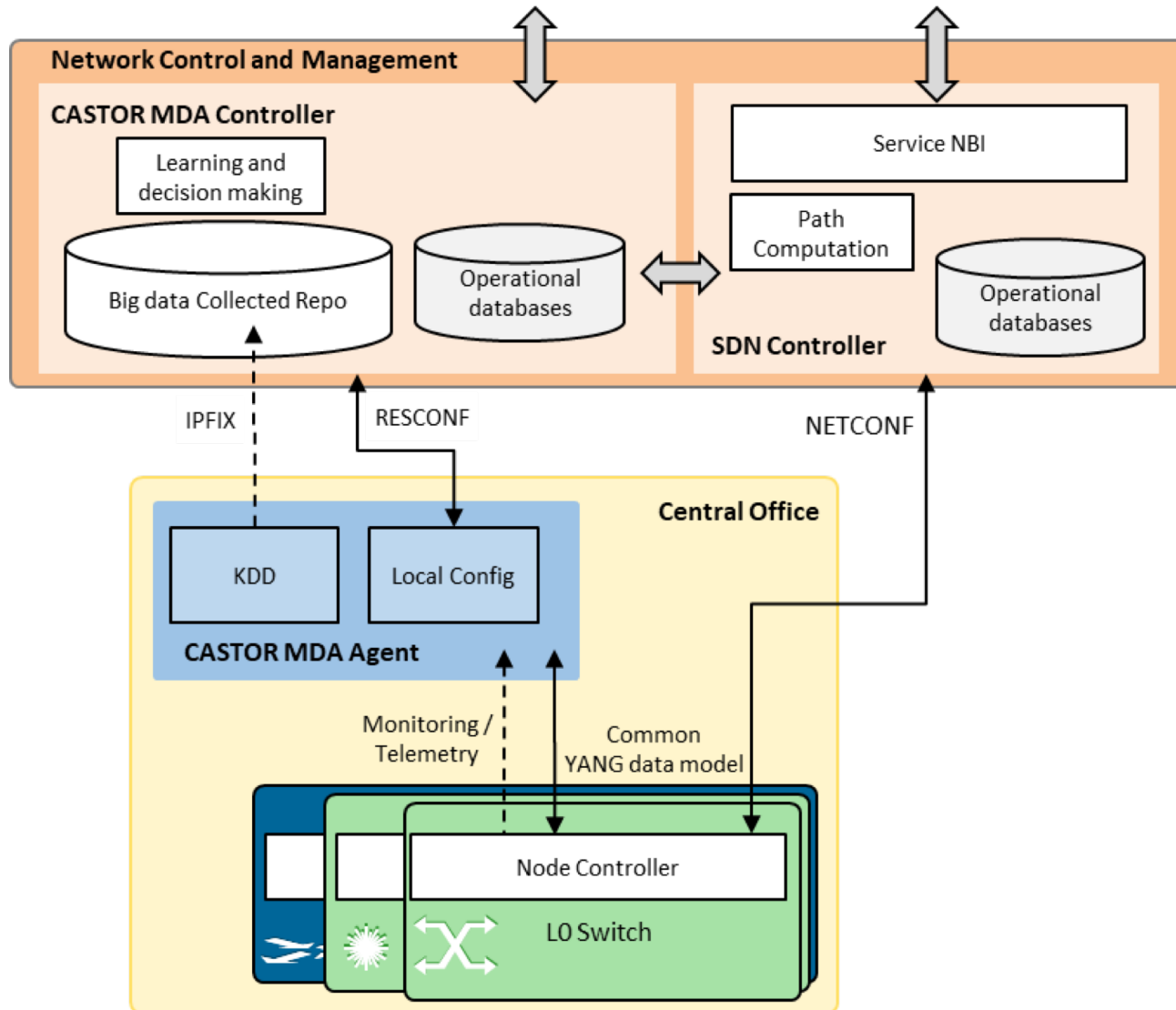

# NFV Support

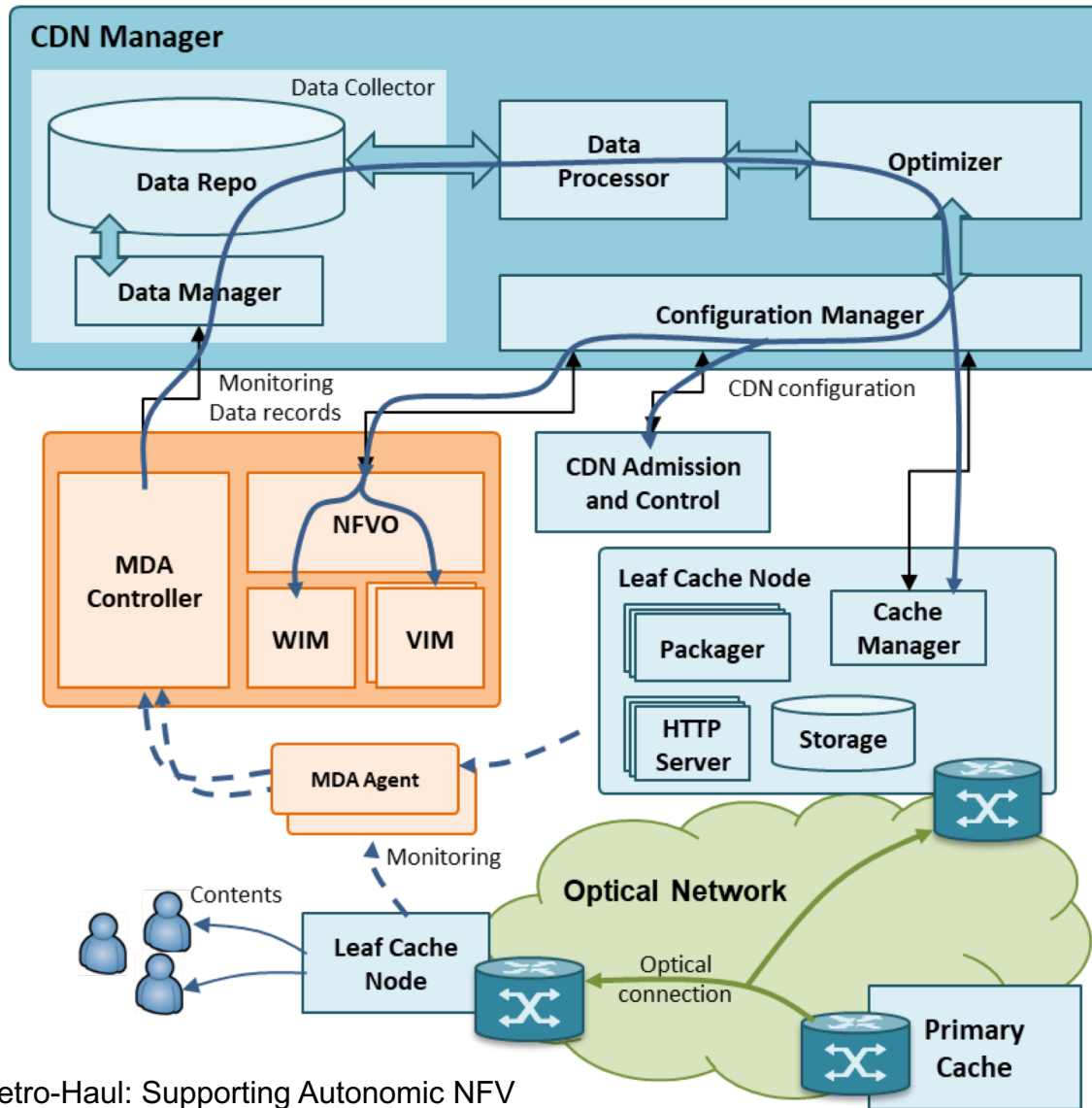

R. Casellas et al., "Metro-Haul: Supporting Autonomic NFV Services over Disaggregated Optical Networks," EuCnC, 2018.

# Network Slicing Support

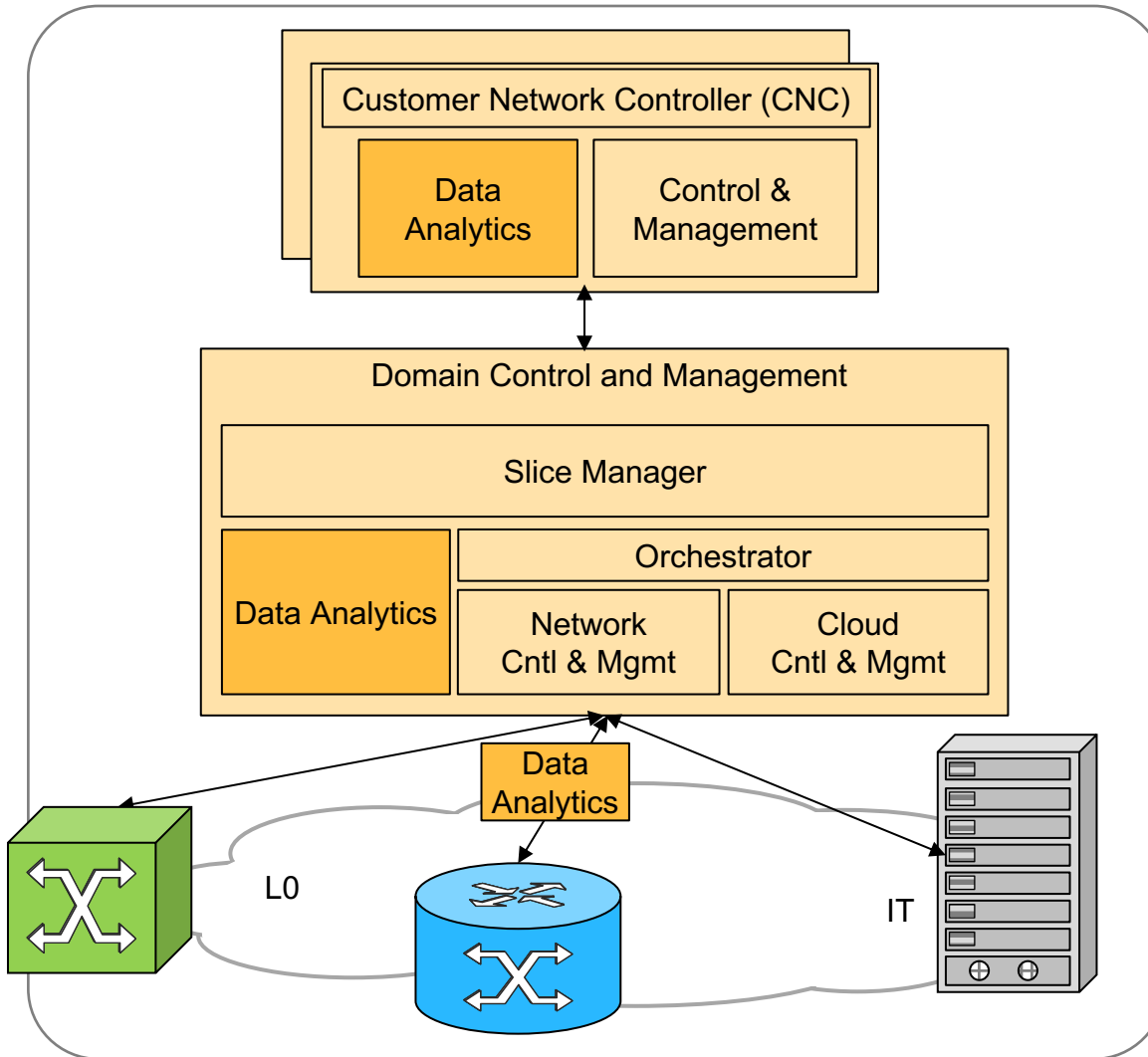

Pattern evaluation and presentation

Data mining and machine learning  
Decision Making

Network Slices

Pattern evaluation and presentation

Data mining and machine learning  
Decision Making

Operator Resources

Transformation  
Decision Making

Pre-processing  
Collection



# Example of Network Slicing

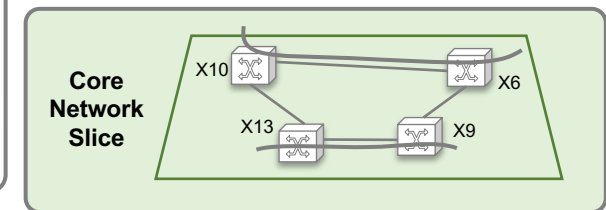
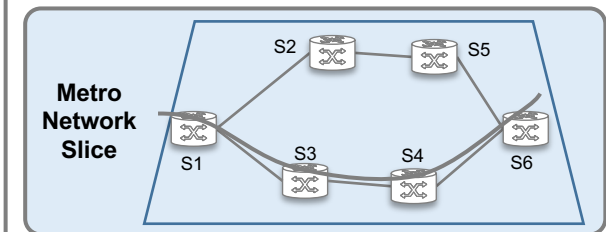
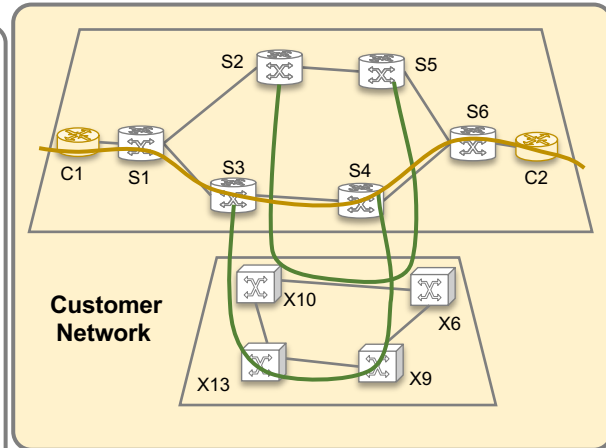
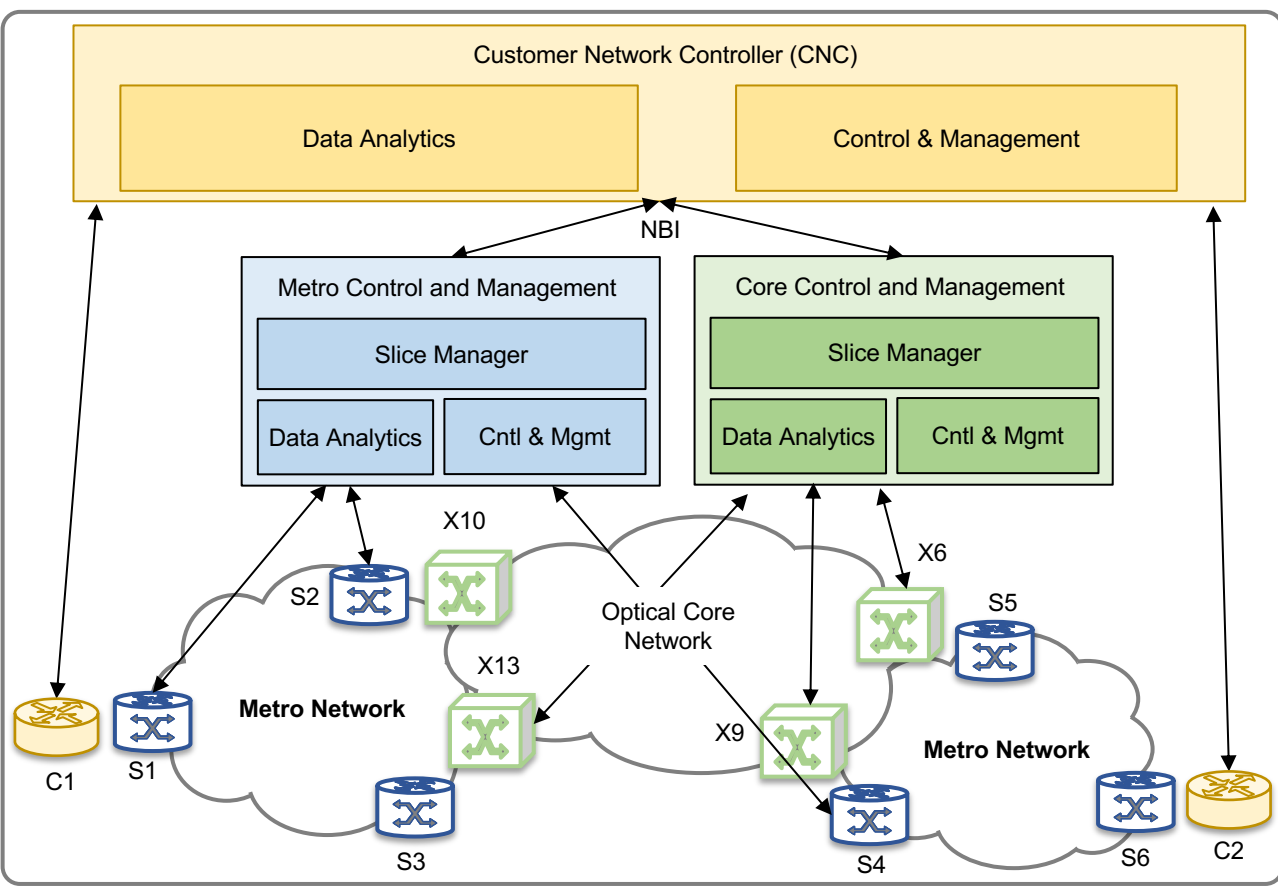

L. Velasco, et al., "An Architecture to Support Autonomic Slice Networking [Invited]," *IEEE/OSA JLT*, 2018.

# Architecture

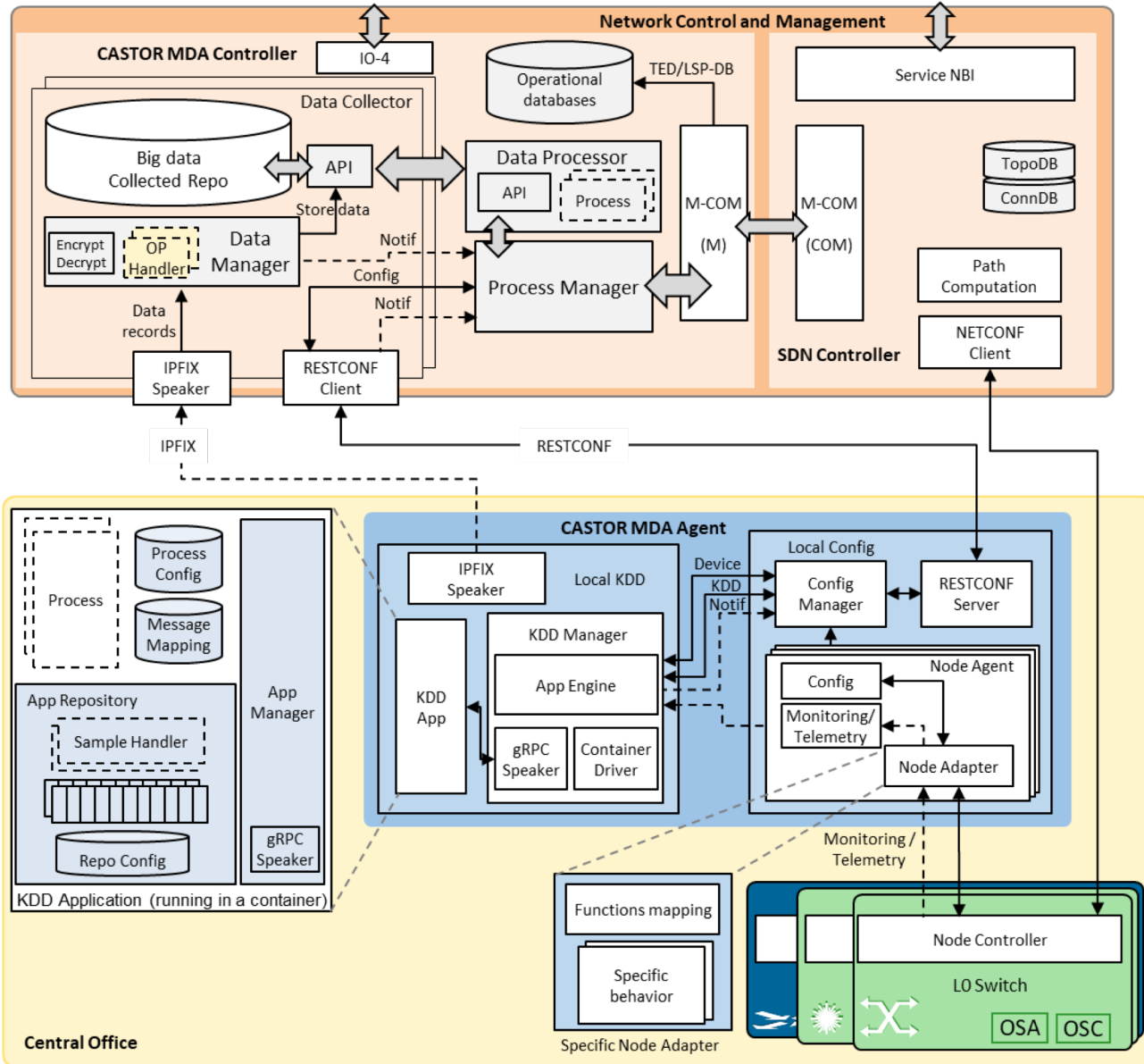

LI. Gifre et al., "Autonomic Disaggregated Multilayer Networking," in IEEE/OSA JOCN, 2018.



UNIVERSITAT POLITÈCNICA  
DE CATALUNYA



# Sample Applications

# VNT Design and Reconfiguration Options

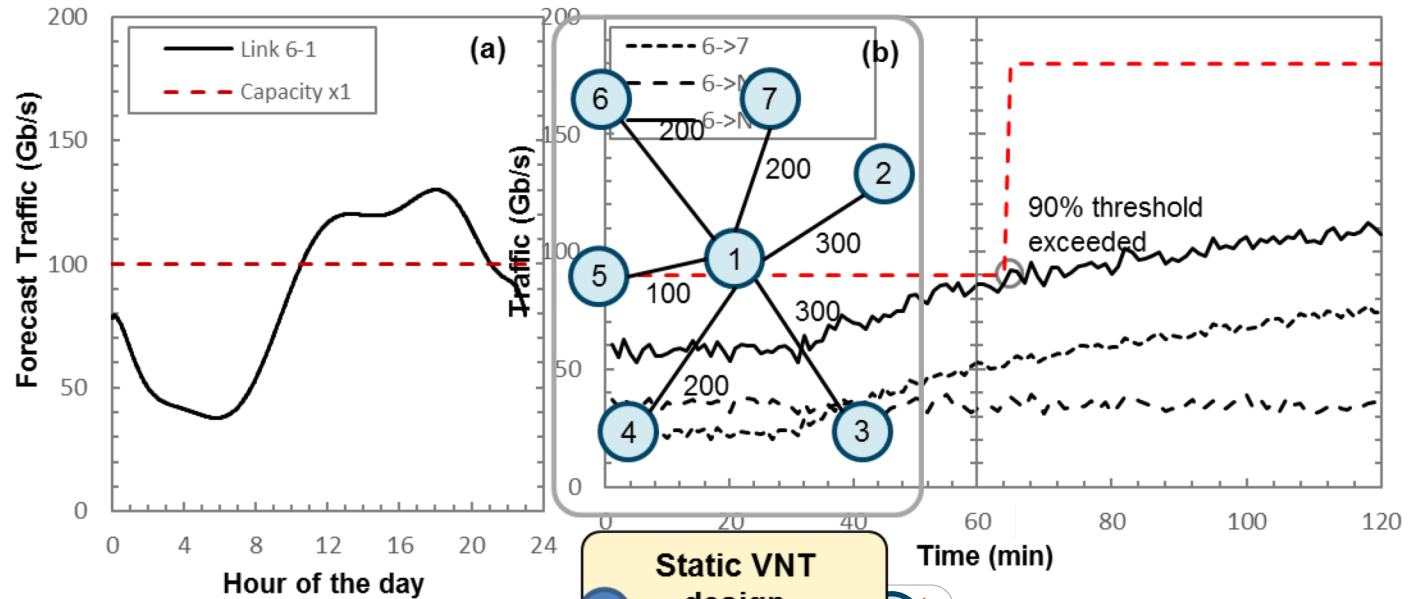

Current VNT

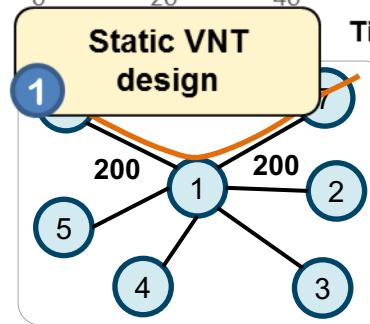
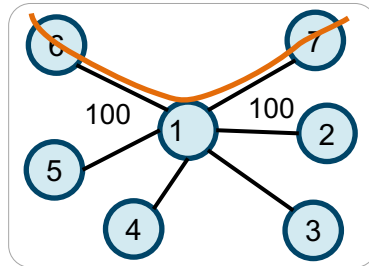

1  
2  
Threshold-based reconfiguration

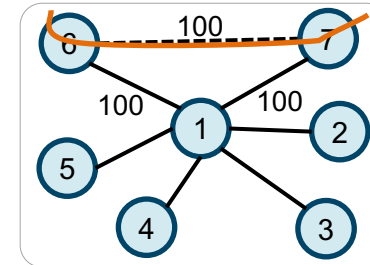

3  
Reconfiguration based on OD traffic prediction

F. Morales et al., "Virtual Network Topology Adaptability based on Data Analytics for Traffic Prediction," *IEEE/OSA JOCN*, 2017.

# BER Degradation Detection and Failure Identification

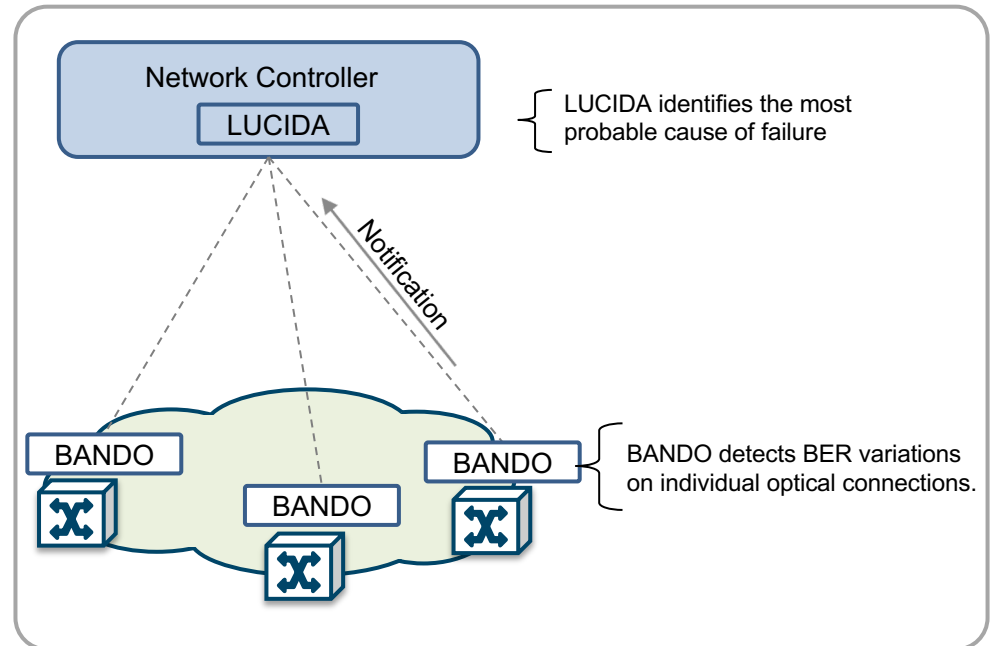
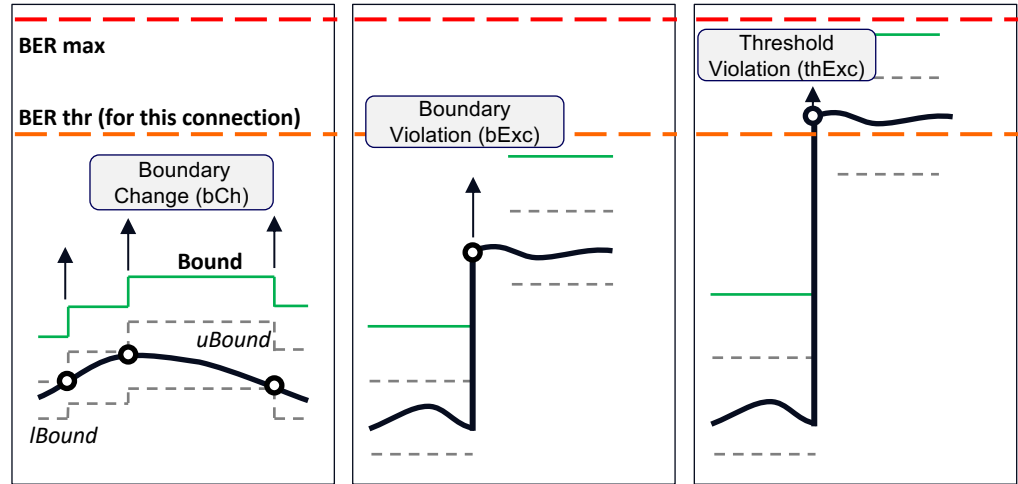
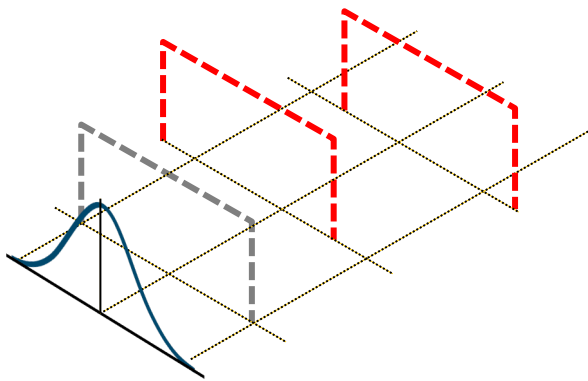
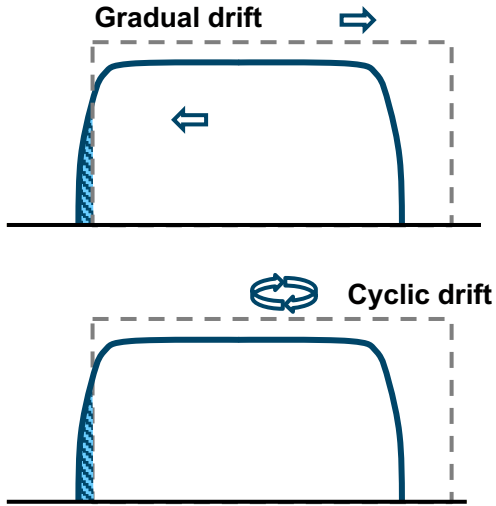

A. P. Vela, et al. "BER Degradation Detection and Failure Identification in Elastic Optical Networks," IEEE JLT, 2017.

# Analyzing the optical spectrum

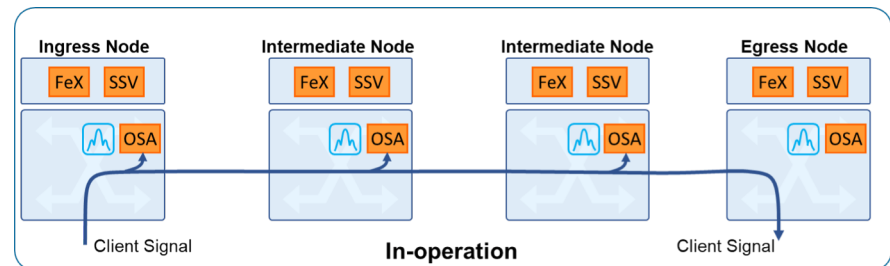
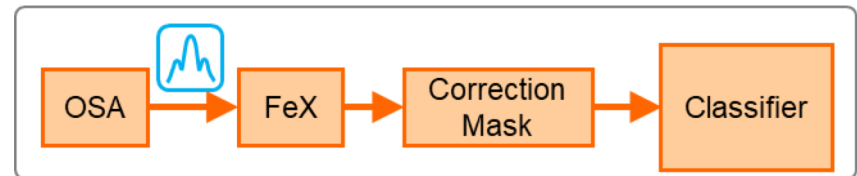
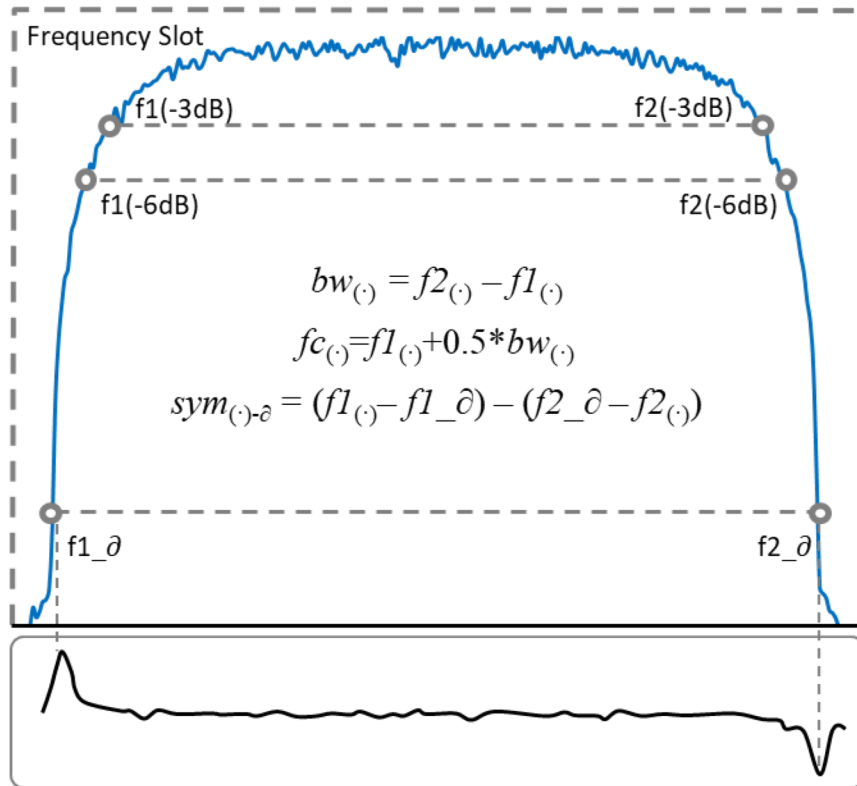

A. P. Vela et al., "Soft Failure Localization during Commissioning Testing and Lightpath Operation [Invited]," *IEEE/OSA JOCN*, 2018.

# Failure Localization

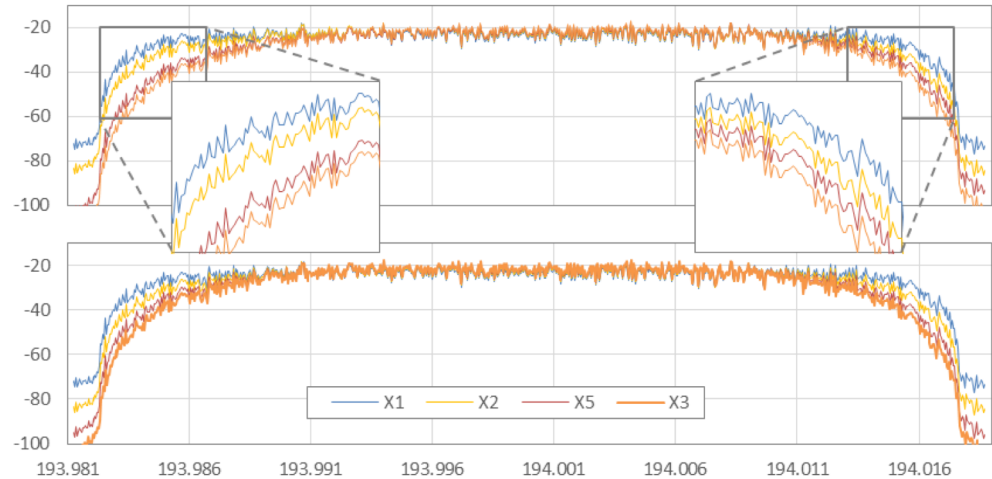
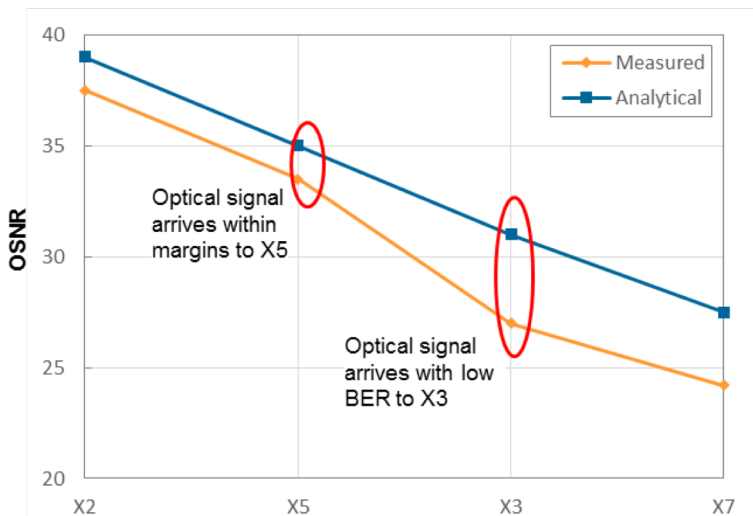
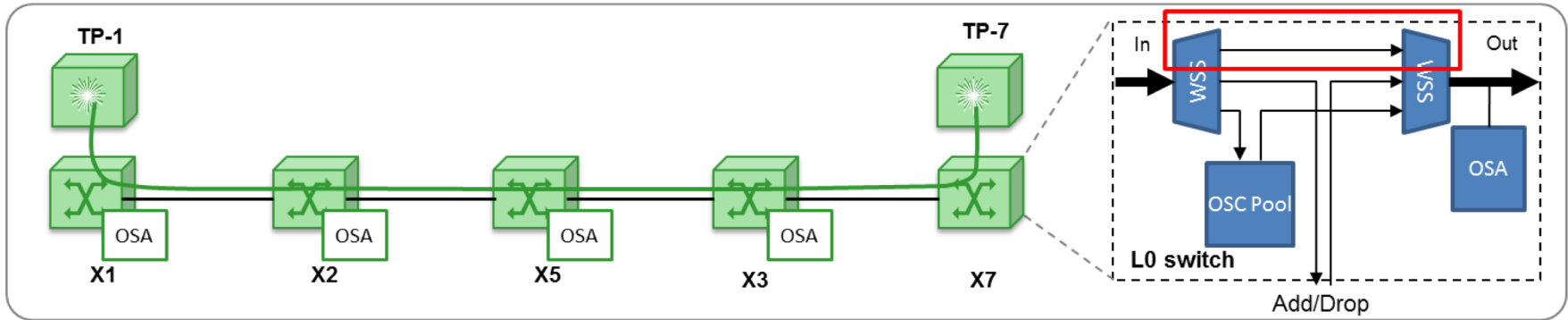

A. P. Vela et al., "Soft Failure Localization during Commissioning Testing and Lightpath Operation [Invited]," *IEEE/OSA JOCN*, 2018.

# Task-oriented Visualization

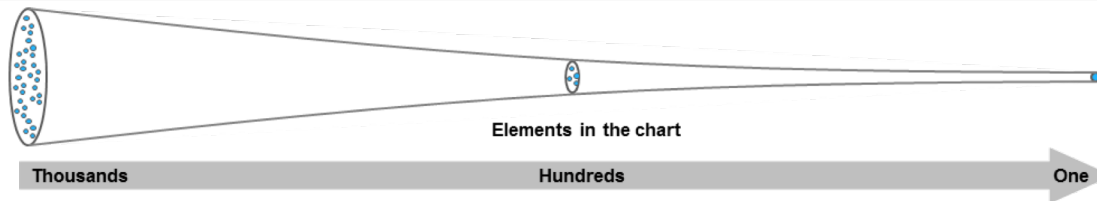
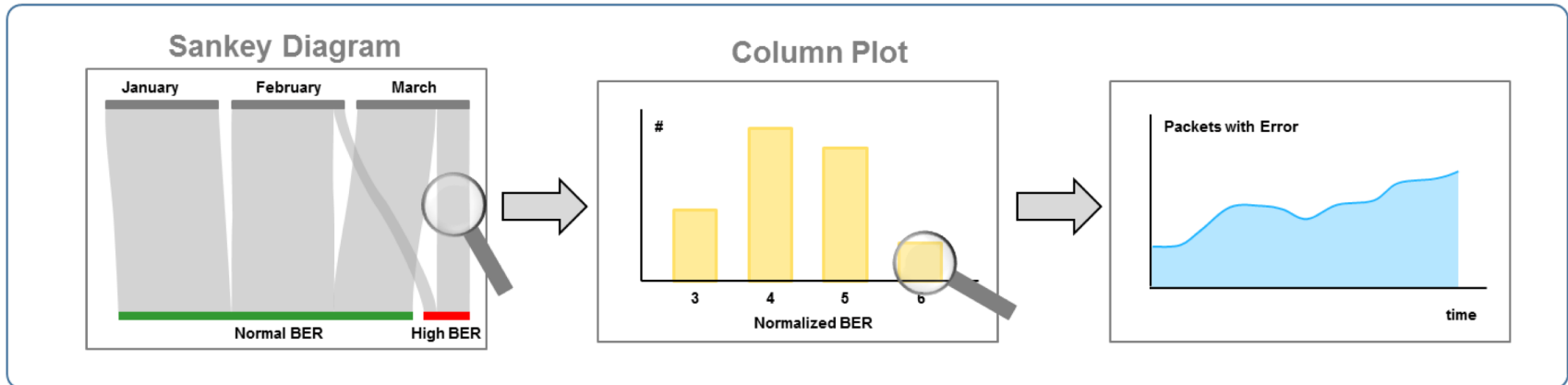
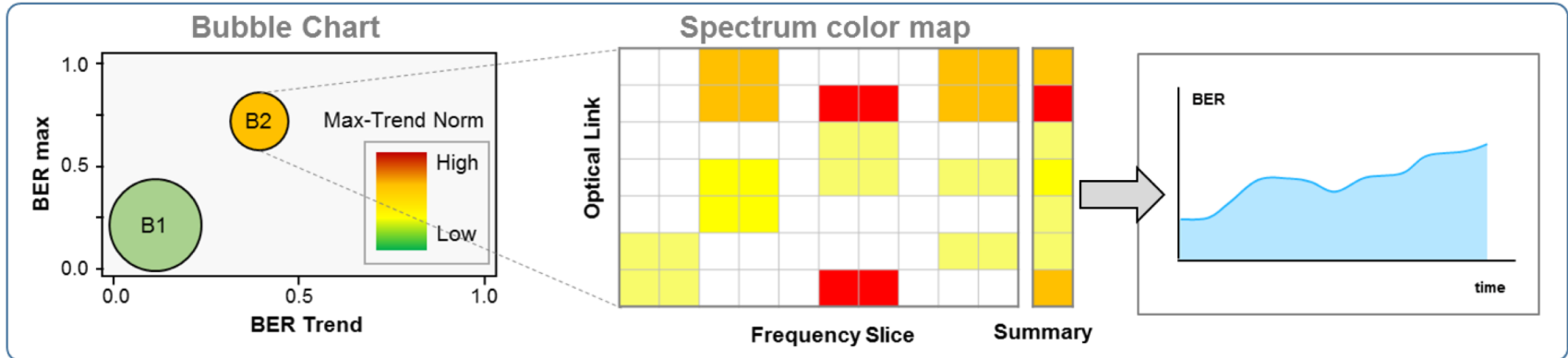

A. P. Vela et al., "Applying Data Visualization for Failure Localization," in Proc. OFC, 2018.





UNIVERSITAT POLITÈCNICA  
DE CATALUNYA



# Demonstration

# Demo Set-up

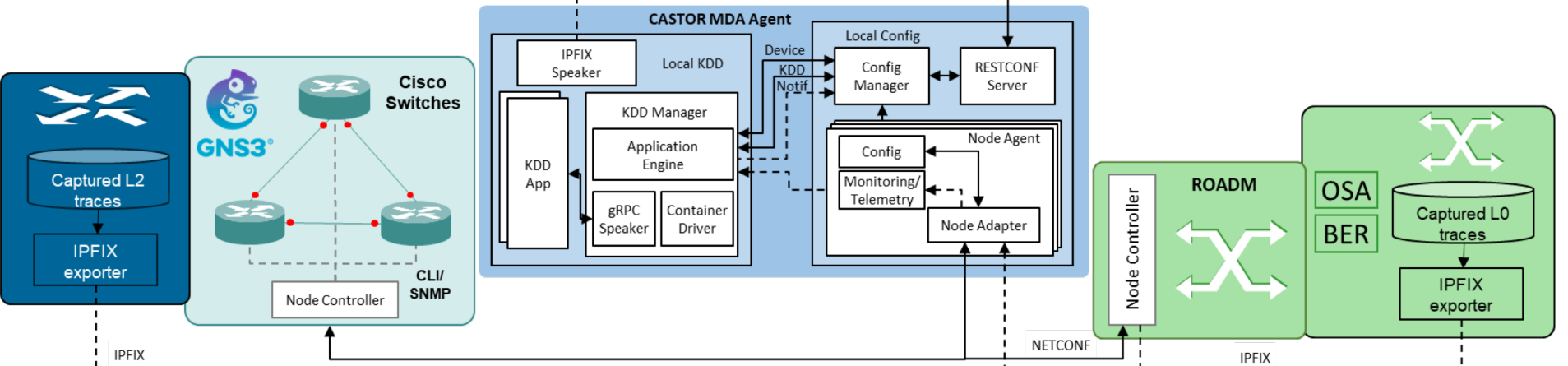
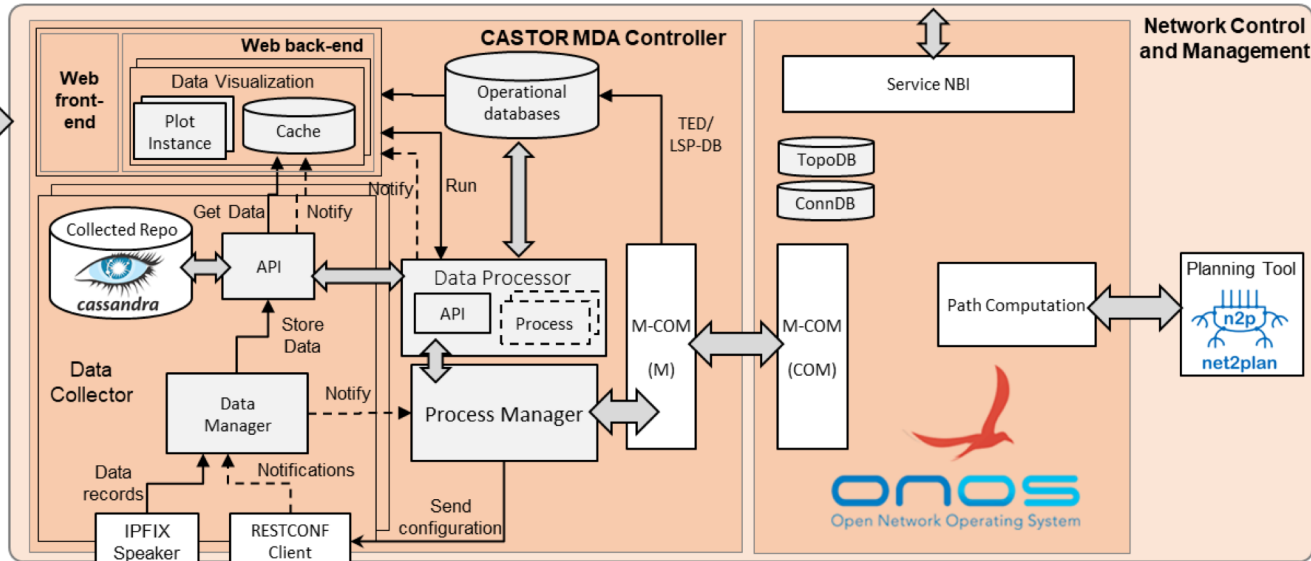
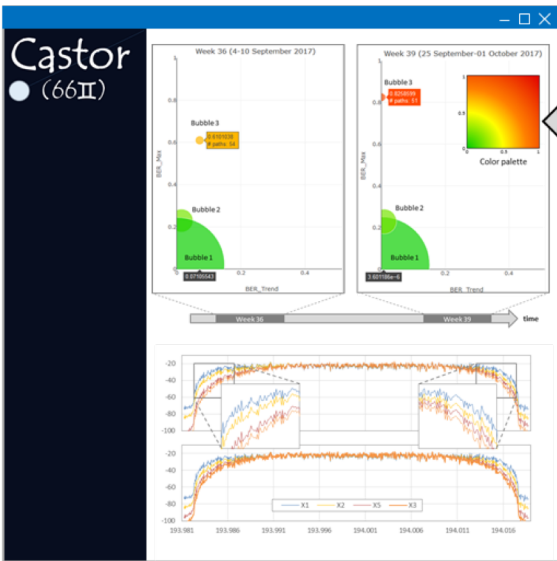

# Examples

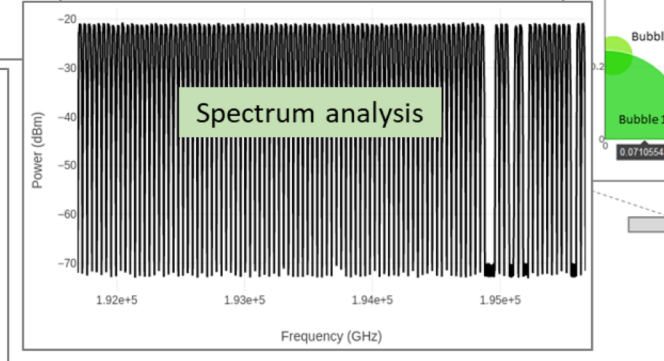
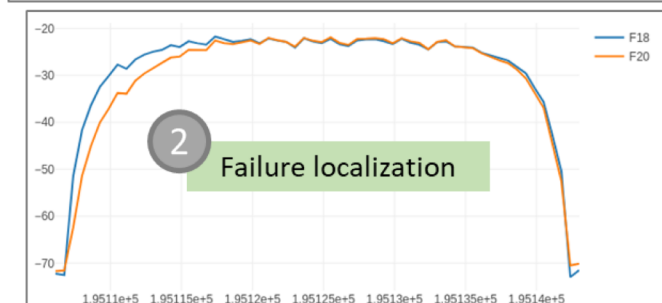
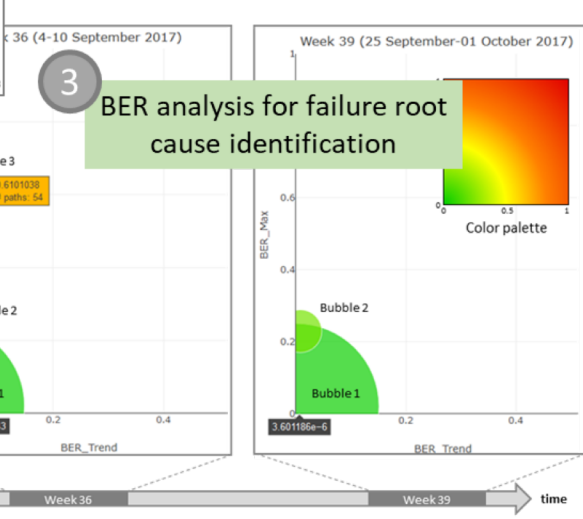
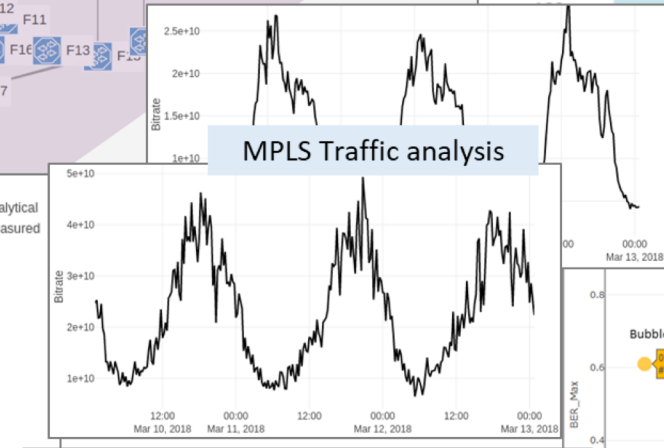
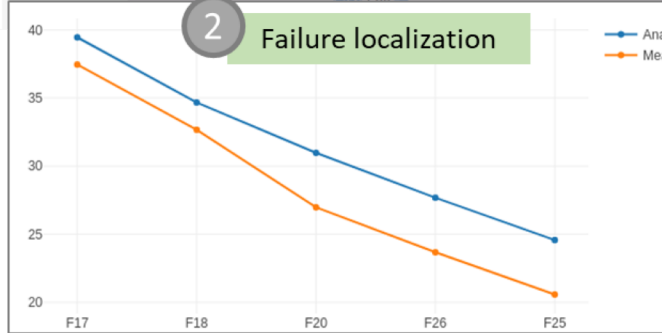
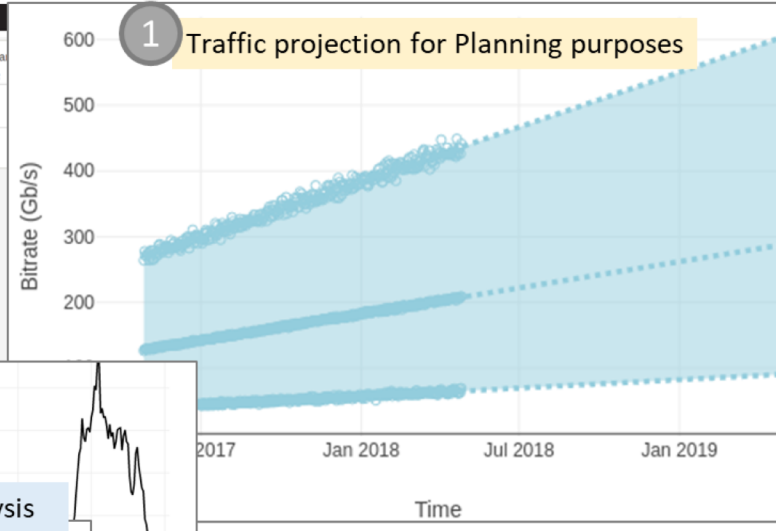
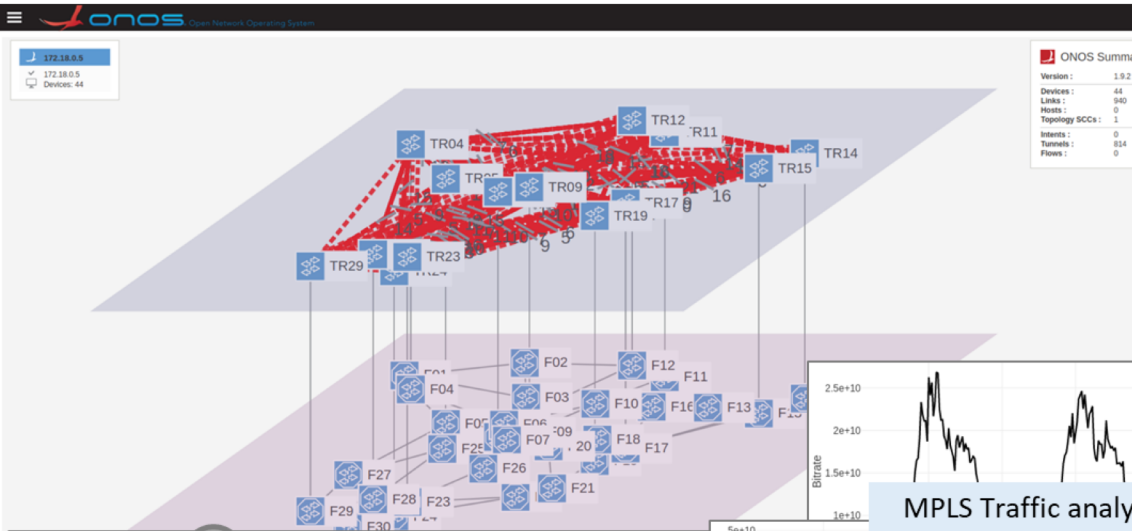



# Thank you!

## The role of MDA in the Control and Management plane of Metro Networks

**Luis Velasco**

[lvelasco@ac.upc.edu](mailto:lvelasco@ac.upc.edu)